



9b j]fcb a YbhU`m Zf]YbX`m d\chcgYbg]h]jY gYb



DfcXiWhZibWh]cb

FÈ ÇÔâÙD ÜUPÙ
 Ü^]|æ&^ Ú@[c[!^•â•c[!•ÇÔâ•DÉÜ[PÙ Ô[{]|äæ}&^ÜàÈ-!^!ÖâÈ-!^!È
 GÈ ŠÖÖ È +Xt
 æåb~•c àæ&*!|~}å |ä*@c æ~c[{ æcä&#||žŠÖÖÉä [ää|^]@4 }gÉ&æž ^fæÖ [{ ž~c^! Öæ { ^!æ:^c&Èg Z B
 HÈ +X¾44/ý y '—> ñ ¼
 Ù Xba|* ž f æ|| \äðâg {žä*@c &[}c[|]|: [ä~w• æ}å |ä*@c &[}c[|]|c [{ ' Ö ±

DfcXiWh 8]a Ybg]cbg

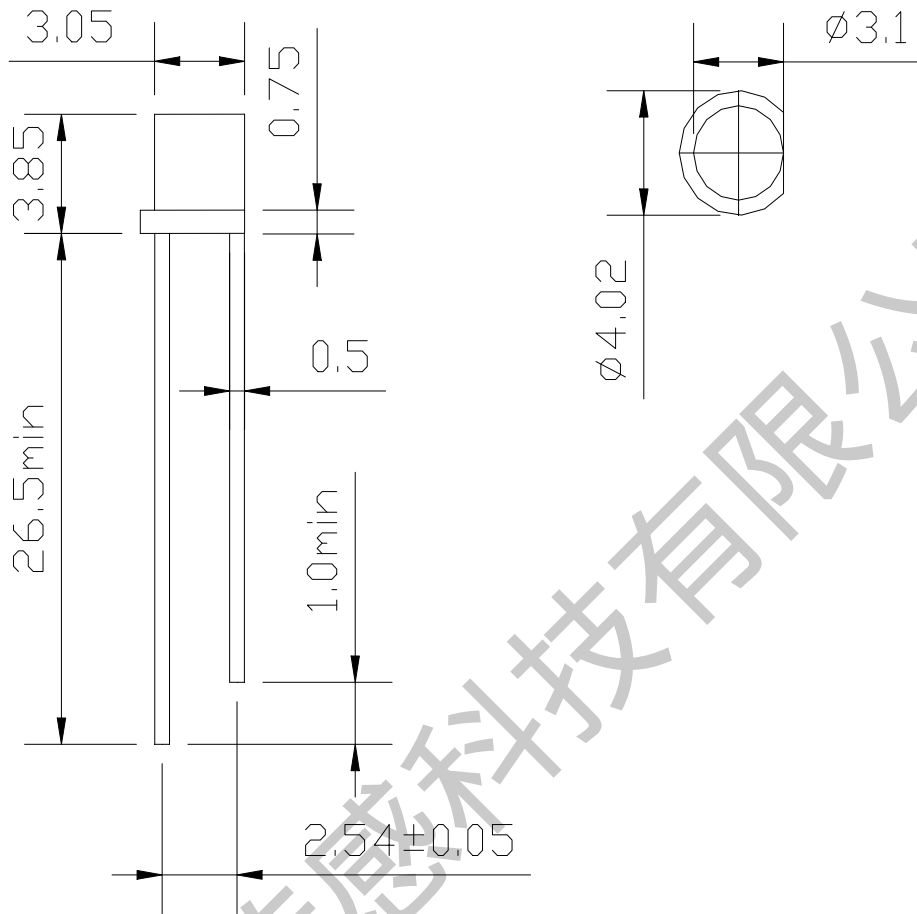

BchY

FÈ

@cb[Zcch dcg]h]jY dc`Y G\cfh d]b bY[Uh]jY

{ { È {€ÈFÍ { {

I b]h. a a - \$"%) a a

GÈ

H\Y UddYUfUbWY Wc`cf cz Wc``c]X g\U`` VY giV^YWh hc h\Y gUad`Y

..

%"\$a a

Dfchf iXYX fYg]b i bXYf h\Y VUgY]g %" \$a a aUI]i a "

HU1&) A5L-A I A F5H=B ; fIH5 1 &) š 7Ł

Úæ!æ { ^c^! }æ { ^	Ù^ { à[Üæcâ } *	W}âc
Ë Ô [^&c [iËÖ { âcc^! X [cæ* ^	Xóóu	GËG€	X
Ë Ò { âcc^!ËÖ [^&c [i X [cæ* ^	Xóóu	í	X
Ô [] • ~ {] cá [}	Ú&	ï€	{ Y
Y [i \ â } * c^ {] ^!æc~!^	V [] :	ËGí ìí	»Ô
Ùc [iæ* ^ c^ {] ^!æc~!^	V. c*	ËI€ F€€	»Ô

HU1&) 9@97HCF!CDH=75@ 7<5F57H9F=GH=7G fIH5 1 &) Ł

Úæ!æ { ^c^!	Ù^ { à[V^•câ } * & [] âcâ [] •	Tâ}Ë	V^]â&æ Xæ]~^	TæçÈ	W}âc•
	QsçFD	XóóMÍXÉ ÒxMF€Š~ç	Fì	Gí	H€	µ€
Ú@ [c [Ë&~] ^ } c	QsçGD	XóóMÍXÉ ÒxMÍ€Š~ç		Öí		µØ
	QsçHD	XóóMÍXÉ ÒxMF€€Š~ç		Gí€		µ€
Öæ! \ Ö] i ^ } c	QÖÖU	XÖÖMÍXÉÒçM€Š~ç			€ÈG	µ€
&						
Ú@ [c [• ^ } • âcç^] ^æ\]]	a		ìí€		} {
, æç^ Ö } * c @ »						
Ù^ } • âcçâc± , æç^] i æ } * ^	â	a	uí€	¿	F€íÈ	}ç
7 7 7 7 7 7 [

Ö

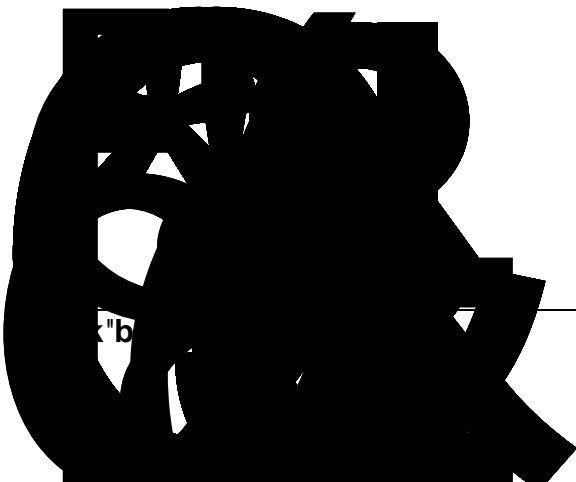

HYgh gW\Y a Uh]W

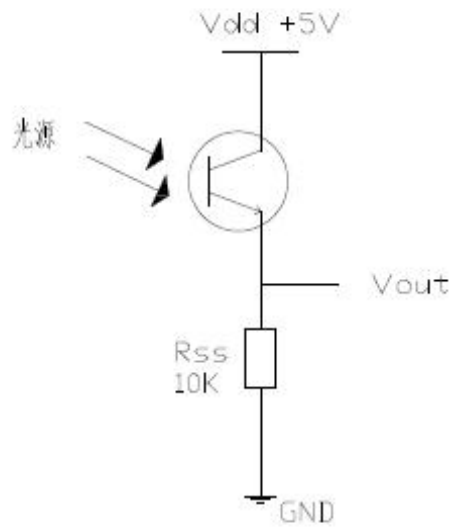

Ú@[c[&~!!^}c MXI~d ÜÜÜ
E ÜÜÜ É
Pã* @ •cæà|^|^•i•cæ}&^ i•|^&[{ {^}â^â~[; ÜÜÜ

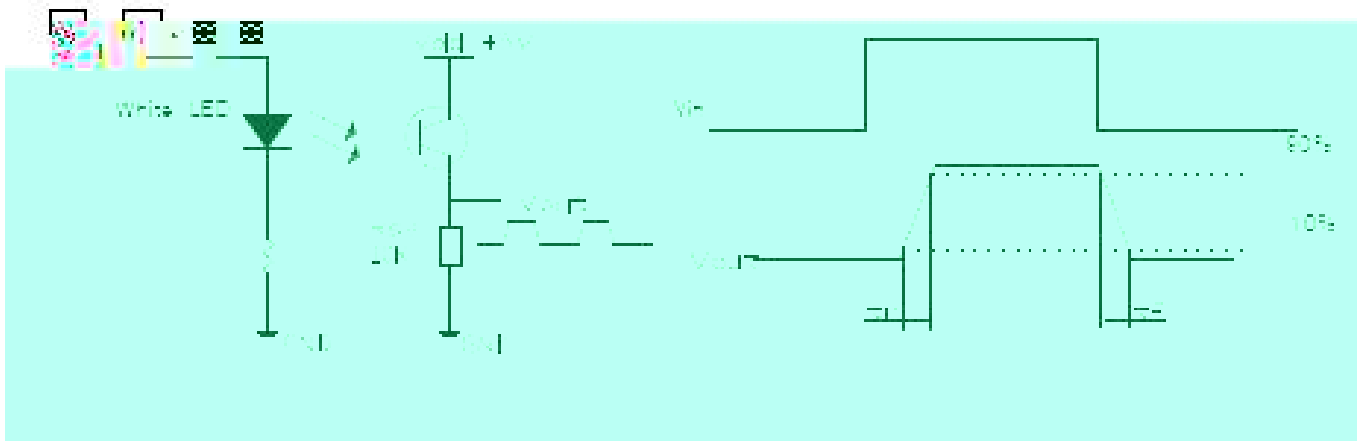

T^æ•~|^ {^}c {^c@[â [- • ,

FYZYfYbWY Wjfw ijh

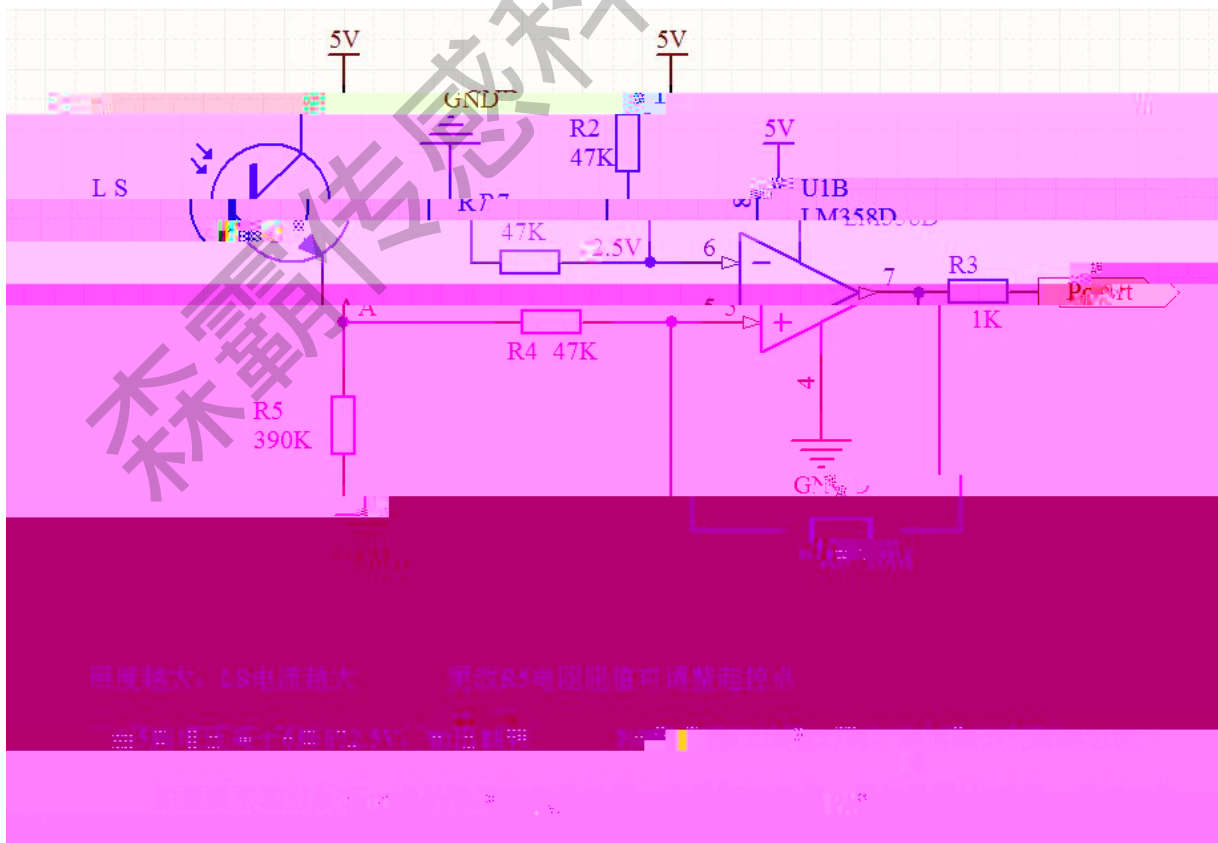
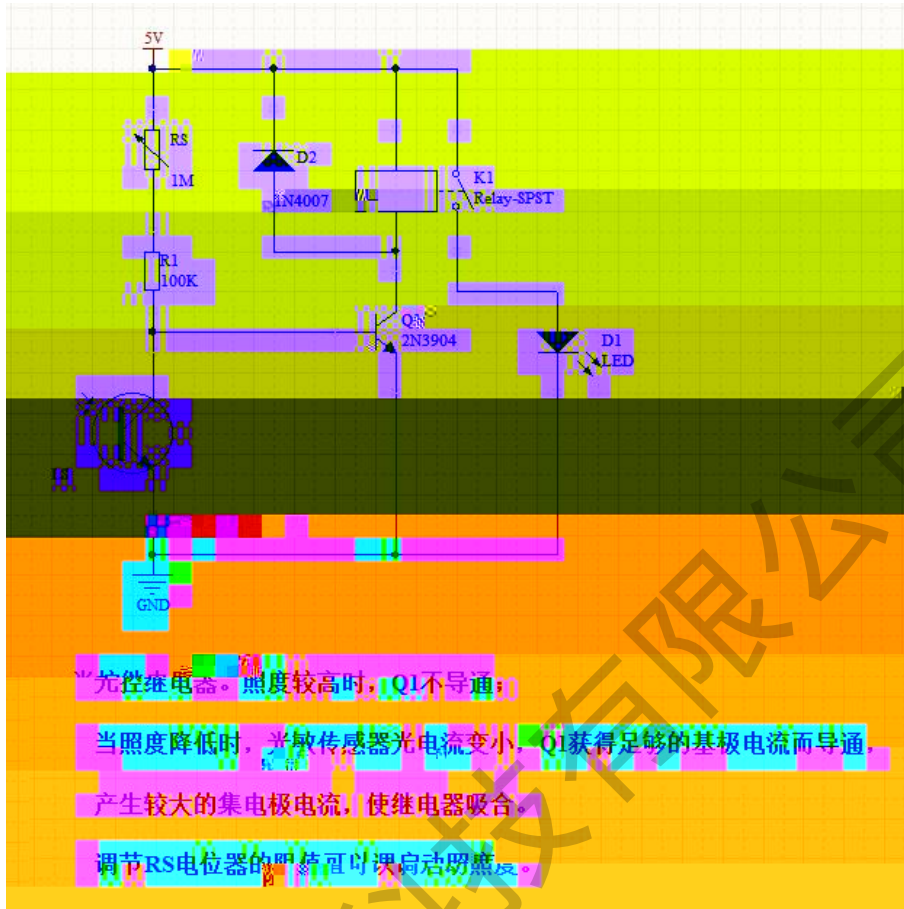



HmdJWU` d\chcY`YWhf]W W\UfUWhYf]gh]Wg W i f j Yg

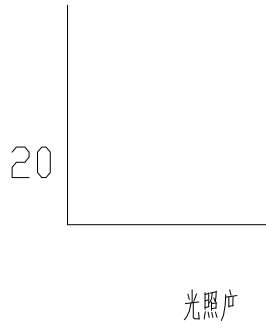

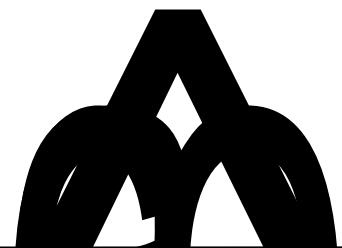
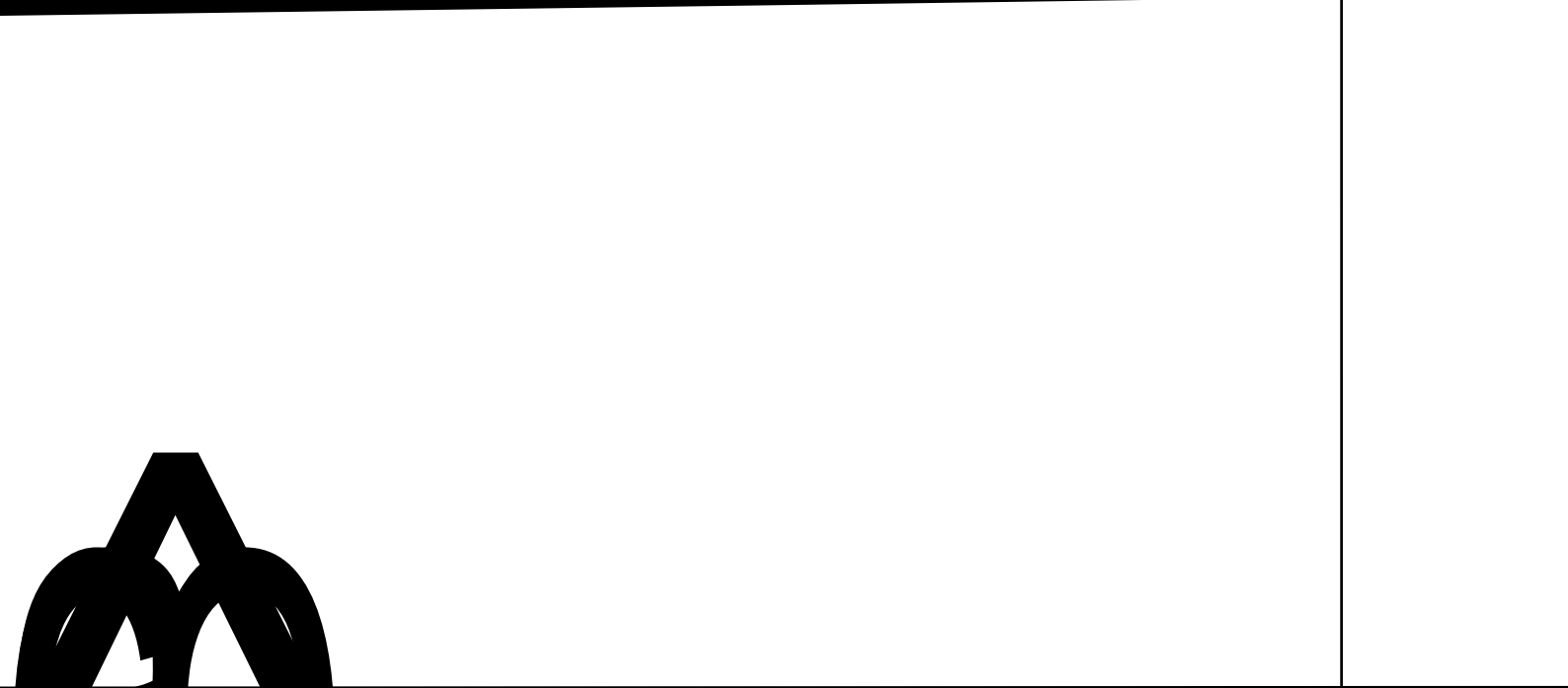
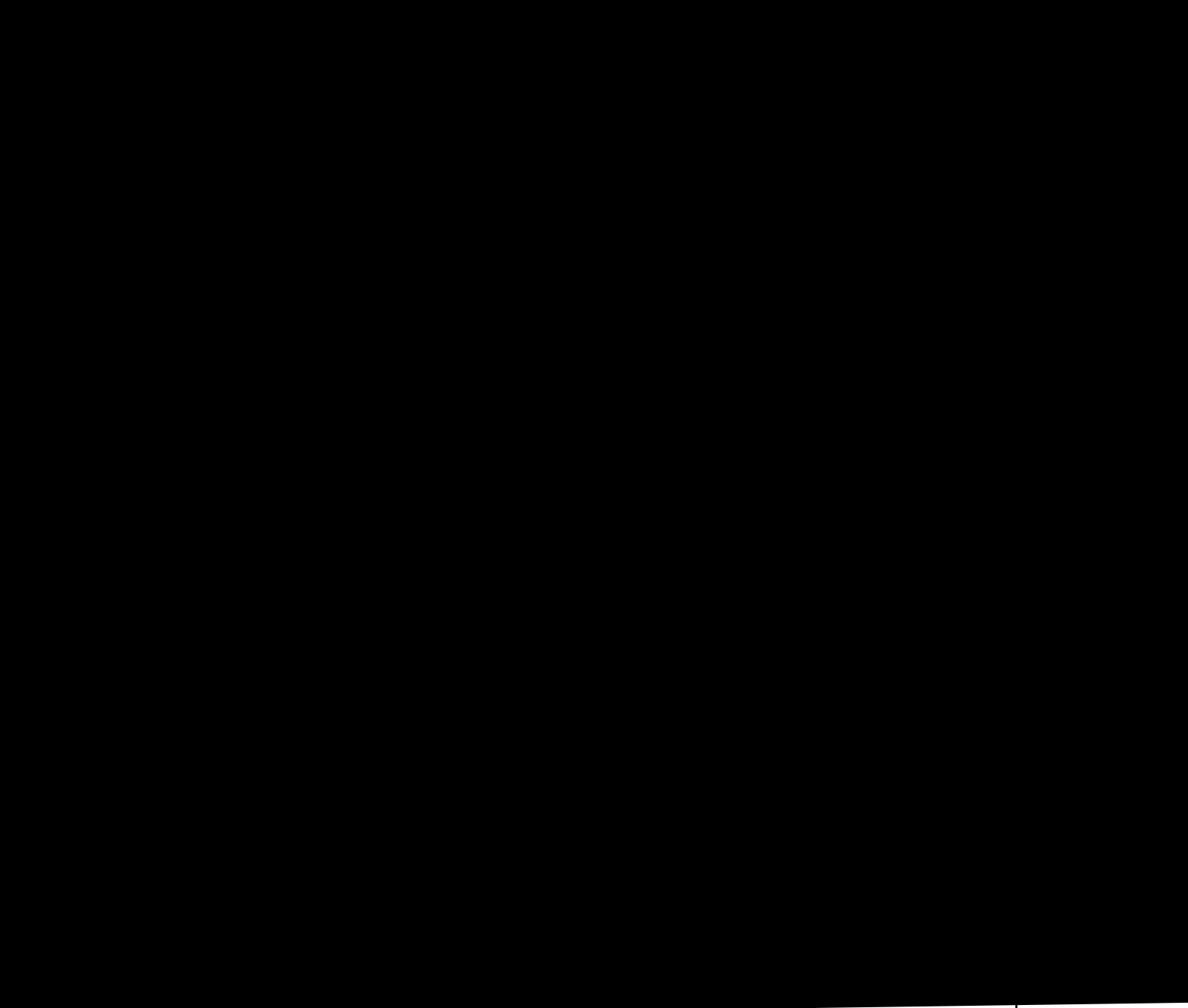



FYWc a a YbXYX Gc`XYf]b [7 cbX]h]cbg

T [å^

Ô [} åâcâ [}

Tæ } ÿ æ || ^



DfYWU ih]cbg

% " € ÉH€»Ô ï€Ã H

H

V@^ •c[!æ*^ &[}ââcâ[] • [~ c@^]:[â~&c æ-c^! |^æçâ} * c@^ -æ&c[!^ •@æ|| à^ € c[É H€ » ÔÉ c@^

!^|æçâç^ @~ {âââc^ •@æ|| } [c à^ { [!^ c@æ} ï€ÃÉæ}â c@^ •c[!æ*^]^!â[â •@æ|| à^ H { []c@•É Q- c@^

•c[!æ*^]^!â[â â • { [!^ c@æ} H { []c@•É c@^]:[â~&c •@æ|| à^]æ&^â } æ &[•^â &[}æâ}^! , âc@

}âc[!^*^ } [! â^•â&&æ}cÉ æ}â c@^ •c[!æ*^]^!â[â {æ^ à^ ~ } c[[]^ ^æ!

& " € ÉH€»Ô

@ ñî€Ã •] • È ã É ~ c È ↑ @

U}&^ c@^]æ&\æ*^ â • []^}^âÉ c@^]:[â~&c •@[~!â à^ ~ •^â ~]æ • •[[]æ •] [••â|^ É Q- âc â • } [c

~!â ~]Éc •@[~€ -H È{ æ ã c ~! | ^ ^ É Èâ ^ â

€ É H € » Ô ï € Ã H

